

HEAVY DUTY ACCESS DOOR  
FOR LARGE OPENINGS

LHD

INSTALLATION

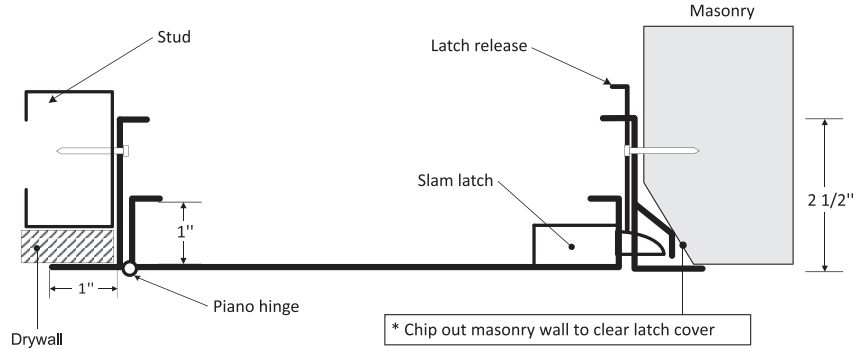

DIMENSIONS AND APPEARANCE

LEED ready: This product contributes to LEED® credits.

DOOR SIZE - W x H INCHES (MM)	NUMBER OF LOCKS	WEIGHT LBS KG	
48 x 48 (609 x 914)	2	64	29
Any size made in record time			
Rough wall opening = door size + 1/4" or + 6mm			

**ACCESS DOORS  
MADE FAST!**

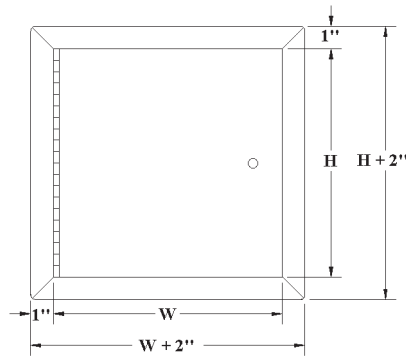

DESCRIPTION AND MATERIAL SPECIFICATION

- Material:** 16 gauge cold rolled steel
- Hinge:** continuous piano hinge
- Lock / latch:** self latching tool-key operated slam latch and/or ring operated slam latch, both included
- Inside panel release:** standard on all doors
- Finish:** high quality white powder coat primer
- Packaging :** individually wrapped, 1 per box

**POPULAR OPTIONS:**

- Material:** stainless steel 304 #4 (brushed finish),
- Lock / latch:** key operated cylinder cam latch, handle operated slam latch, mortise preparation for cylinder (cylinder optional), mortise deadbolt lock
- Design:** double leaf

PROJECT DATA

PROJECT NAME:	QTY	W	H	OPTIONS
ARCHITECT:				
DEALER:				
CONTRACTOR:				
LOCATION:	SPECIAL INSTRUCTIONS:			
DATE:				
TAGGING INSTRUCTIONS:	SUBMITTAL APPROVAL: (signature or stamp)			