

DRAFT STOP ACCESS DOOR
FOR ATTIC APPLICATION

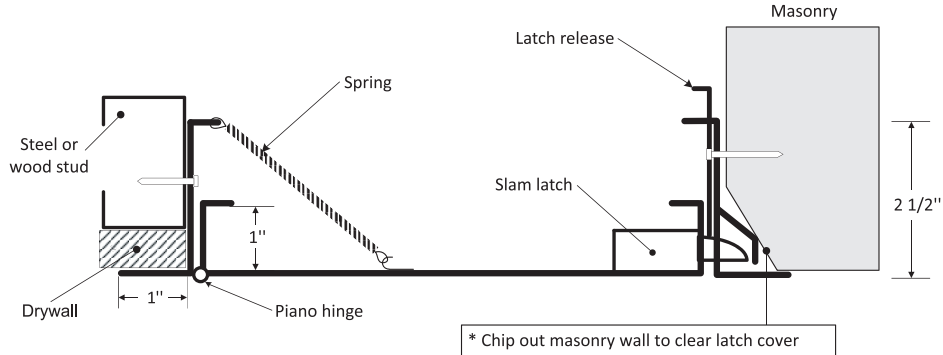

INSTALLATION: WALLS ONLY



DIMENSIONS AND APPEARANCE

LEED ready: This product contributes to LEED® credits.

DOOR SIZE - W x H INCHES (MM)	NUMBER OF LOCKS	WEIGHT LBS KG
22 x 30 (558 x 762)	1	22 10
22 x 36 (558 x 914)	2	24 10.9
24 x 36 (609 x 914)	2	29 12.2
24 x 48 (609 x 914)	2	37 16.8
24 x 60 (609 x 1524)	2	44 20
30 x 30 (762 x 762)	1	30 13.6
36 x 36 (914 x 914)	2	39 17.7
36 x 48 (914 x 1219)	2	49 22.2

Rough wall opening is door size + 1/4" or + 6mm

**ACCESS DOORS
MADE FAST!**

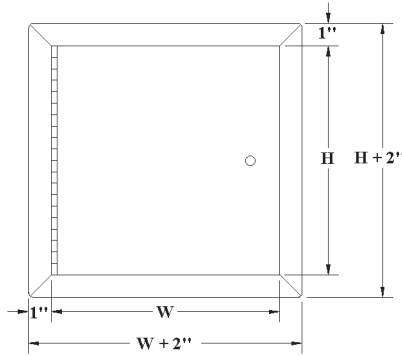

DESCRIPTION AND MATERIAL SPECIFICATION

- Material:** 16 gauge cold rolled steel
- Hinge:** continuous piano hinge
- Lock / latch:** self latching tool-key operated latch and/or ring operated latch, both included
- Inside panel release:** standard on all doors
- Automatic panel closer:** standard on all doors
- Finish:** high quality white powder coat primer
- Packaging:** individually wrapped, 1 per box

POPULAR OPTIONS:

- Material:** stainless steel 304 #4 (brushed finish)
- Lock / latch:** key operated cylinder cam latch, handle operated slam latch, mortise preparation for cylinder (cylinder optional), mortise deadbolt lock
- Gasketing:** neoprene gasket

PROJECT DATA

PROJECT NAME:	QTY	W	H	OPTIONS
ARCHITECT:				
DEALER:				
CONTRACTOR:				
LOCATION:	SPECIAL INSTRUCTIONS:			
DATE:				
TAGGING INSTRUCTIONS:	SUBMITTAL APPROVAL: (signature or stamp)			