

HCP-10 / HCG-10 Traffic Doors

Durable, Versatile, Attractive.



HCP-10 & HCG-10 IMPACT TRAFFIC DOORS

These attractive and durable impact traffic doors are designed for use in a wide variety of applications, including grocery, retail, commercial and light industrial. The 1-½" thick door panels are constructed with a structural PVC internal framework, clad with impact resistant ABS face sheets and foamed in place with CFC-Free urethane foam for excellent insulation value. The scratch-resistant acrylic vision panels are 14" x 16" set in black rubber molding. These attractive, durable door panels are textured on both sides and operate on the Easy Swing Hinge System pioneered by Eliason more than thirty years ago, and still the smoothest-operating and most reliable hinge system on the market today. The HCG-10 has full perimeter gasketing for cooler applications.



Eliason HCG-10 / HCP-10 Doors

product features
& specifications



Durable, versatile,
and attractive.

- HCP-10 and HCG-10 represent the **most durable impact traffic doors** available for a wide variety of applications including grocery, retail, commercial and light industrial.
- Attractive textured door panels are constructed with a structural PVC internal framework, clad with impact resistant ABS face sheets available in a variety of colors.
- These doors operate on the Easy Swing Hinge System patented by Eliason.
- The HCG-10 Door comes with a full perimeter edge gasket for walk-in cooler applications.

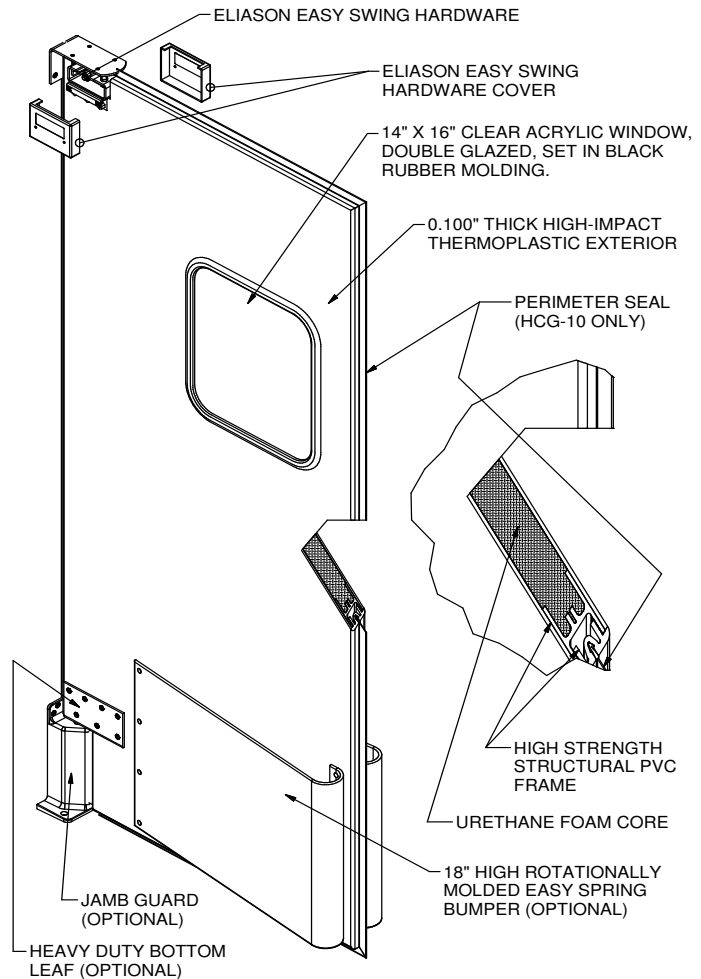

Applications

- Commercial
- Industrial
- Supermarket
- Retail

Traffic

- Pallet Jack
- Push Cart
- Pedestrian

Specifications

DOOR BODY: Urethane foam core with a high strength structural PVC frame, 1-1/2" total door thickness.

FINISH: .100" thick high-impact thermoplastic exterior.

EASY SPRING BUMPER: Standard 18" high (both sides). Optional: 24", 36" or 42" high bumpers or scuff plates.

WINDOW: 14" x 16" clear acrylic, double glazed set in black rubber molding.

HINGE: Eliason Easy Swing® Hinge.

HCG-10: Same finish as the HCP-10 with perimeter seal.

OPTIONS: Available with optional Easy Spring Bumpers, impact plates, aluminum or steel jamb guards, various window sizes.

Available Colors:



In our continuing effort to improve our products, some specifications or descriptions may change. We reserve the right to make such changes without notice or recourse.



AUTHORIZED ELIASON DEALER:

Metropolitan Door Industries

350 Thorens Avenue

Garden City Park, NY 11040

Toll Free: 888.MDI.DOOR (888.634.3667)

Phone: 516.294.1801

Fax: 516.294.1828

www.metropolitandoor.com